



D8 D6

OFF-HIGHWAY MULTI-VIEW DUMPER TRUCKS



**THE MOST COMPACT**



D8

D6

<b>INFORMACION GENERAL</b>		<b>D8</b>	<b>D6</b>
Capacida de carga	kg	8.000	6.000
Capacidad del tolva nivel de agua	l	3.200	3.200
Capacidad del tolva a ras	l	4.600	4.600
Capacidad del tolva colmada	l	6.100	6.100
Sistema de Descarga		Posterior	Posterior
Puesto de Conductor		Giratorio - Dual View	Giratorio - Dual View
Chasis		Fijo	Fijo
Peso en Vacío	kg	5.100	5.100
Transmision		Hidrostática	Hidrostática
Cabina		Rops-Fops	Rops-Fops
<b>*MOTOR</b>			
Marca		Yanmar	Yanmar
Modelo		4TNV98CT-NYI2D	4TNV98CT-NYI2D
Potencia	kW	53,7	53,7
<b>CARACTERISTICAS DE CONDUCCION</b>			
Velocidad Maxima	km/h	25 (40 opt.)	25 (40 opt.)
Pendiente Superable	%	50	50
Radio de Giro	mm	4400	4400
Traccion		AWS	AWS
Neumaticos		12.5/80-18 16 PR	12.5/80-18 16 PR
Bloqueo Oscilante Eje		Optional	Optional
<b>SISTEMA HIDRAULICO</b>			
Circuito Hidraulico		Bomba doble gera	Bomba doble gera
Presion de Trabajo	bar	180	180
<b>CIRCUITO ELECTRICO</b>			
Motor de Arranque	V/kW	12/3	12/3
Bateria	V/Ah	12/110	12/110
<b>CAPACIDAD DEL TANQUE</b>			
Combustible	l	125	125
Hidraulico	l	125	125
<b>FRENOS</b>			
Servicio		Hidráulico actuando en ambos ejes	
Escalera		Hidráulico que actúa sobre los ejes traseros	
<b>HOMOLOGACION</b>			
Homologación vial (italiana)		Sí	Sí

\*Motor Stage IIIA disponible

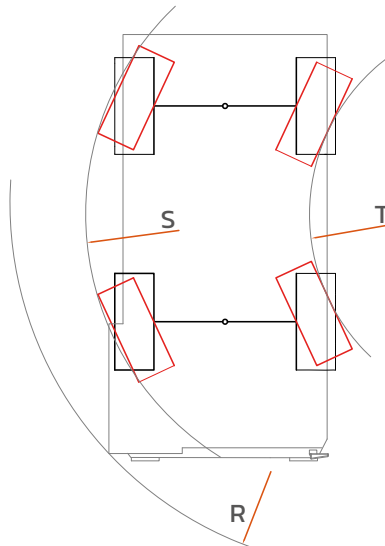
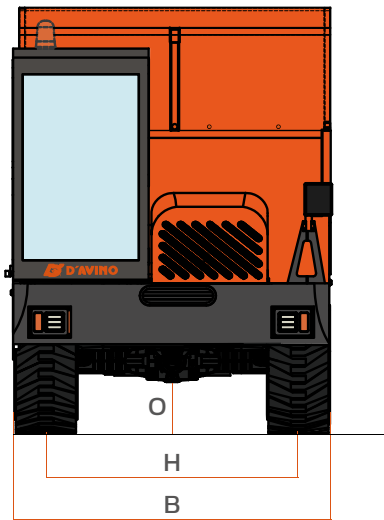
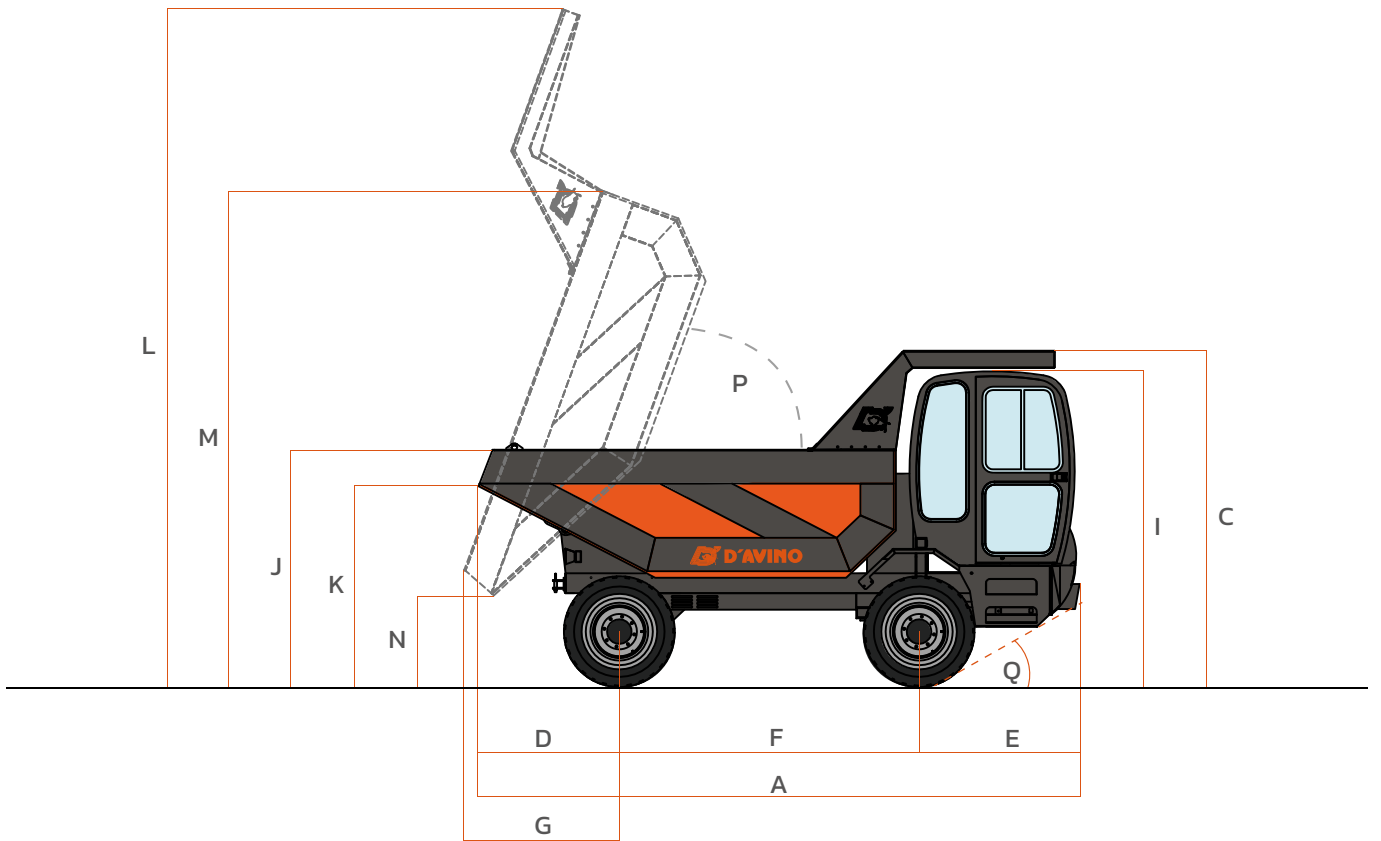

	<b>D8</b>	<b>D6</b>
<b>A</b>	4645	4645
<b>B</b>	2000	2000
<b>C</b>	3170	3170
<b>D</b>	1230	1230
<b>E</b>	1285	1285
<b>F</b>	2130	2130
<b>G</b>	1490	1490
<b>H</b>	1665	1665
<b>I</b>	2780	2780
<b>J</b>	2280	2280
<b>K</b>	1865	1865
<b>L</b>	5530	5530
<b>M</b>	3560	3560
<b>N</b>	880	880
<b>O</b>	300	300
<b>P</b>	70°	70°
<b>Q</b>	31°	31°
<b>R</b>	4400	4400
<b>S</b>	4000	4000
<b>T</b>	2000	2000



AMOG srl | I-80031 Brusciano (NA) | Tel. +39 081 658 8361 | [sales@davinogroup.biz](mailto:sales@davinogroup.biz)

[davinodumper.com](http://davinodumper.com)